

Tunnel Dettenberg

Renewal of a single lane railway tunnel in Switzerland

INFO

Scheifele



Tunnel Heading Machine Schaeff - Terex ITC 420



The Heading and Loading Machine Schaeff model ITC 420 excavation of the invert with the bucket



Accurate excavation thanks to the tilt and swivel console

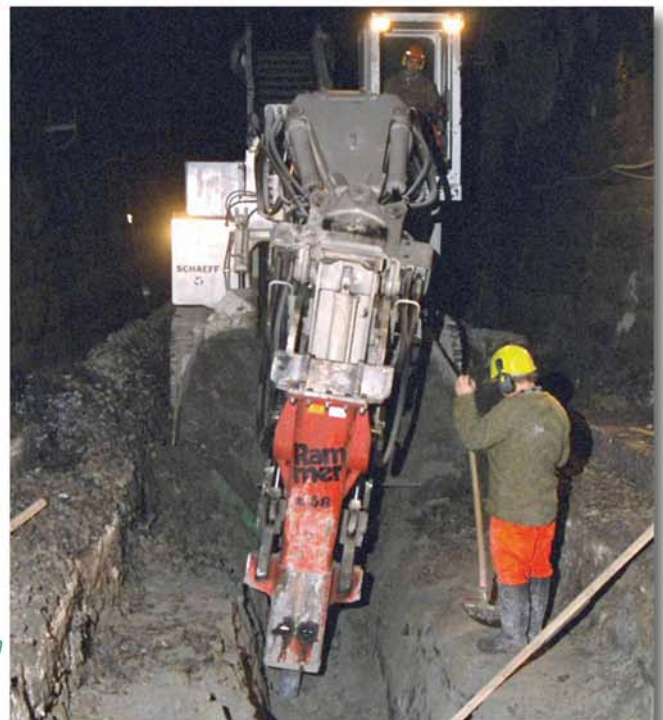

Trenching in limestone with the integrated hydraulic hammer



INTER TECHNO COMMERCE SA

122, Rue de la Fusion Fax: +41-277 222 185
CH - 1920 - MARTIGNY Tf: +41-277 222 191
<http://www.itcsa.com> e-mail: info@itcsa.com



TEREX

SCHAEFF

MAIN DATA

Base Machine: Schaeff type	ITC	420
Maximum chassis width:	mm	2500
Apron throat width	mm	1000
Electric drive power (400V-50Hz)	kW	110
Diesel Engine Power output	kW	120
Driving speed:	km/h	0-3,6
Conveyor chain speed:	m/s	0.5
Loading capacity	m ³ /min	2-5
Specific ground pressure:	kp/cm ²	1.0
Traction power:	kN	380
Weight	t	40



Material transport with the articulated dump truck Paus model ITC 8000

Tunnel Heading Machine

Schaeff - Terex **ITC 420**

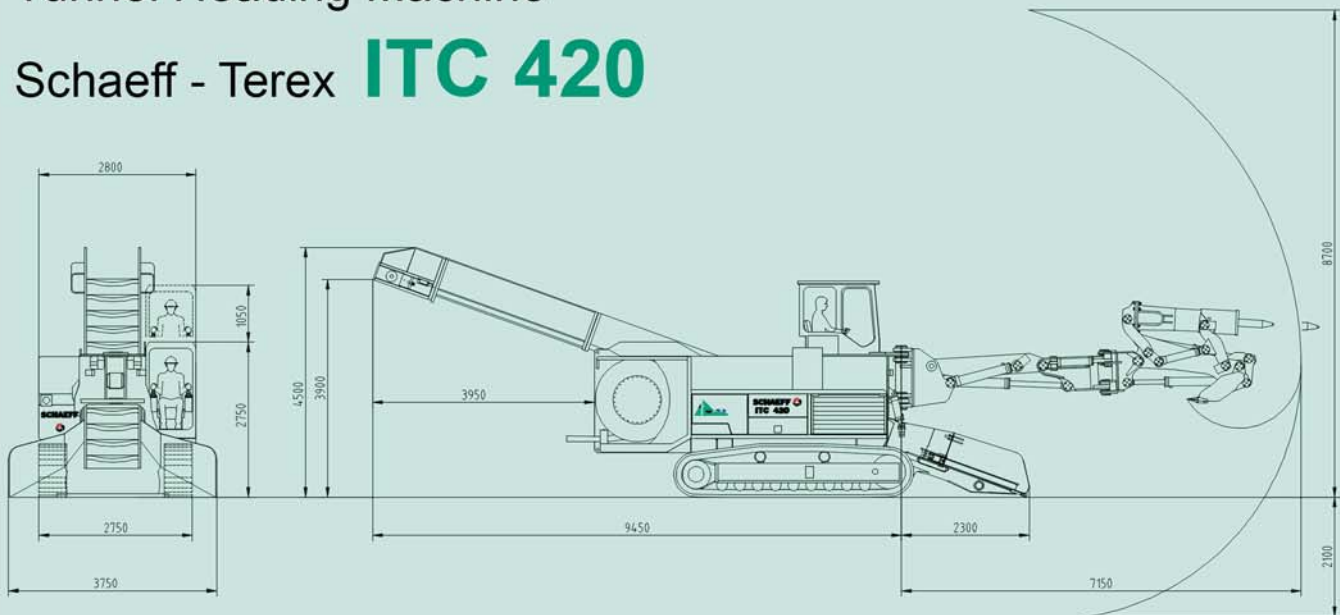

The Tunnel Heading Machine Schaeff model ITC 420



... hammer and bucket, exchanged in few seconds