

Tunnel Tridel

Railway tunnel for a waste treatment plant in the city of Lausanne (Switzerland)

INFO

Tunnel Heading Machine Schaeff - Terex

ITC 320-V45



The Heading and Loading Machine Schaeff model ITC 320 producing big blocks and few dust



Profiling the lifters with the integrated hammer



Loading onto crane skips



INTER TECHNO COMMERCE SA

122, Rue de la Fusion Fax: +41-277 222 185
CH - 1920 - MARTIGNY Tf: +41-277 222 191
<http://www.itcsa.com> e-mail: info@itcsa.com



SCHAEFF

LOSINGER

Tunnel Heading Machine

Schaeff - Terex **ITC 320-V45**

The holly Barbara

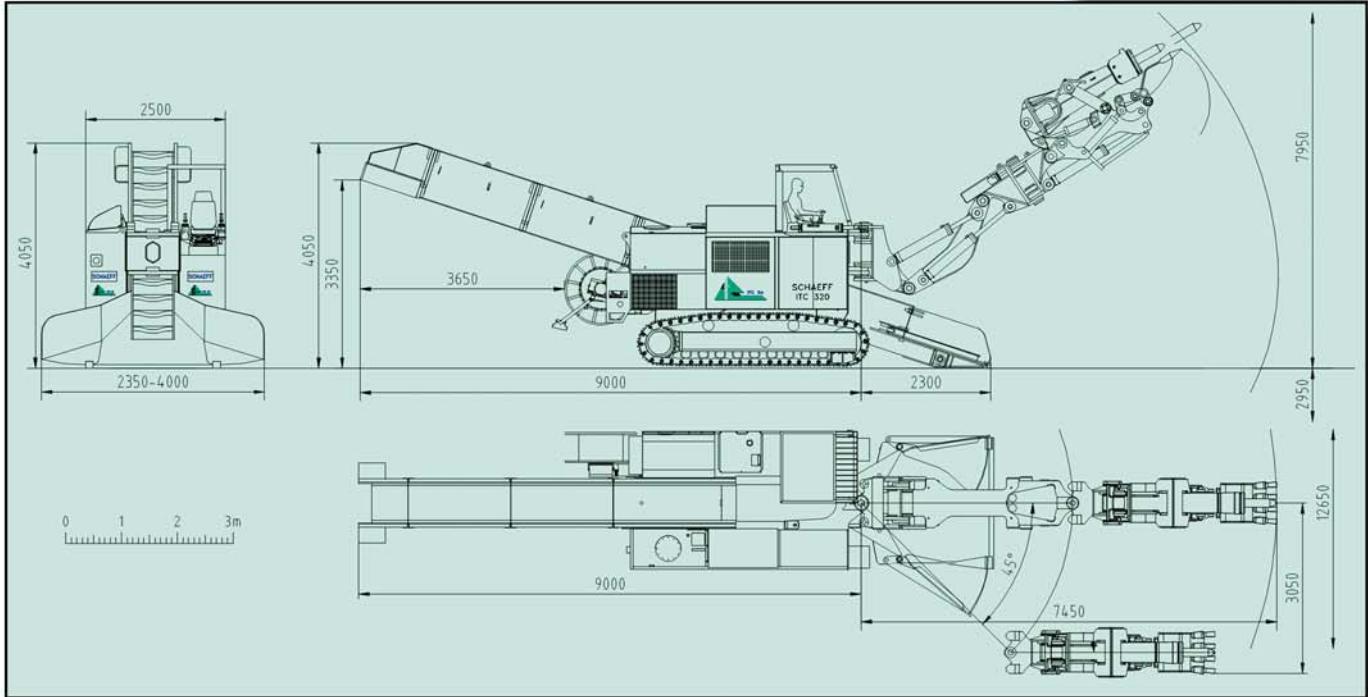

MAIN DATA

Base Machine: Schaeff type	ITC	320
Maximum chassis width:	mm	2500
Apron throat width	mm	770
Electric drive power (400V-50Hz)	kW	110
Diesel Engine	Deutz Typ	BF4M 1013
Power output	kW	102
Driving speed:	km/h	0-3,6
Conveyor chain speed:	m/s	0.5
Loading capacity	m ³ /min	2-3
Specific ground pressure:	kp/cm ²	1.0
Traction power:	kN	380
Weight	t	40



Acurate operation thanks tilt and swivel console



Cleaning the place for the steel arch