

HL-AG, Koralmbahn Graz - Klagenfurt

Baulos B1260 Recognition tunnel Mitterpichling



NEWS
- 24 2005

Tunnel Heading Machine

SCHAEFF-TEREX

ITC 312 H1



Vault heading in hard layers of Schlufton

<p>EISENBAHN- HOCHLEISTUNGS- STRECKEN AG HOCHLEISTUNGSSTRECKEN</p>	<p>Baubeginn: August 2004 Fertigstellung: November 2006 Streckenlänge: 2588m</p>	<p>PLANUNG und BAUÜBERWACHUNG</p>	<p>BAUANSFÜHRUNG</p>
	<p>KORALMBAHN GRAZ - KLAGENFURT</p> <p>Baulos B1260, Erkundungstunnel Mitterpichling</p>		

Project overview



East entrance: Angelika-Tunnel, left the protective Barbara



INTER TECHNO COMMERCE SA
122, Rue de la Fusion Fax: +41-277 222 185
CH - 1920 - MARTIGNY Tf: +41-277 222 191
<http://www.itcsa.com> e-mail: info@itcsa.com



Tunnel Heading Machine

SCHAEFF-TEREX

ITC 312 H1



Quick loading cycle onto 30 to- dump trucks



Excavation of the left vault part

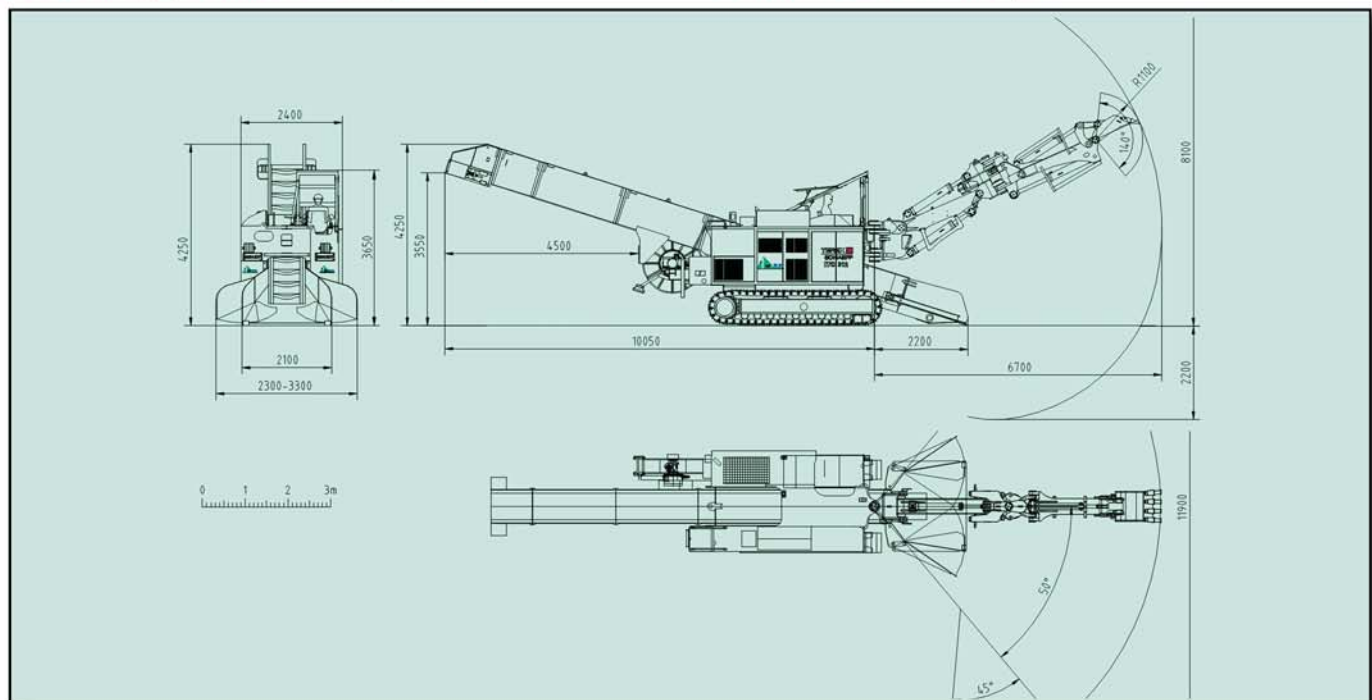

HAUPTDATEN

Base Machine: Schaeff type	ITC	312
Maximum chassis width:	mm	2400
Apron throat width	mm	770
Electric drive power	kW	90
Diesel Engine Deutz, Power output	kW	130
Cable reel capacity	m	90
Driving speed	km/h	0-3,6
Conveyor chain speed	m/s	0,5
Conveying capacity, up to	m ³ /h	250
Specific ground pressure	kp/cm ²	1,0
Traction power	kN	280
Weight approx.	t	30



Acurate excavation thanks to the swivel and tilt console



ARGE

Alpine Mayreder und Beton u. Monierbau