

Tunnel Loading Machine **ITC 312 H3**

NEWS
-31-2008



Arbeitsgemeinschaft "Mähringer Berg"
SCHACHTBAU NORDHAUSEN GmbH • THYSSEN SCHACHTBAU GmbH



bauen den Zugangsstollen zu einem neuen Vorkommen im Kalkbergwerk Märkerkalk in Blaustein (bei Ulm)

Schüttern im Hauptstollen

High force and compact power



Die Tunnellademaschine Typ ITC 312 H3 in Ladeposition im Hauptstollen

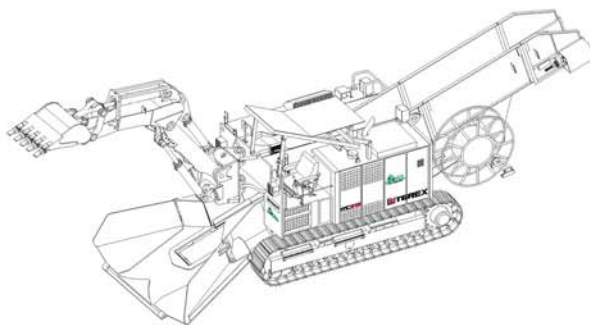

Eingang zum Gabriele-Stollen



INTER TECHNO COMMERCE SA

122, Rue de la Fusion Fax: +41-277 222 185
CH - 1920 - MARTIGNY Tf: +41-277 222 191
<http://www.itcsa.com> e-mail: info@itcsa.com



ES-24.03.2008



The machine ITC 312 im vollen Einsatz



Berauben der Orstbrust in sehr sicheren Bedingungen

Tunnel loading Machine Terex

ITC 312 H3

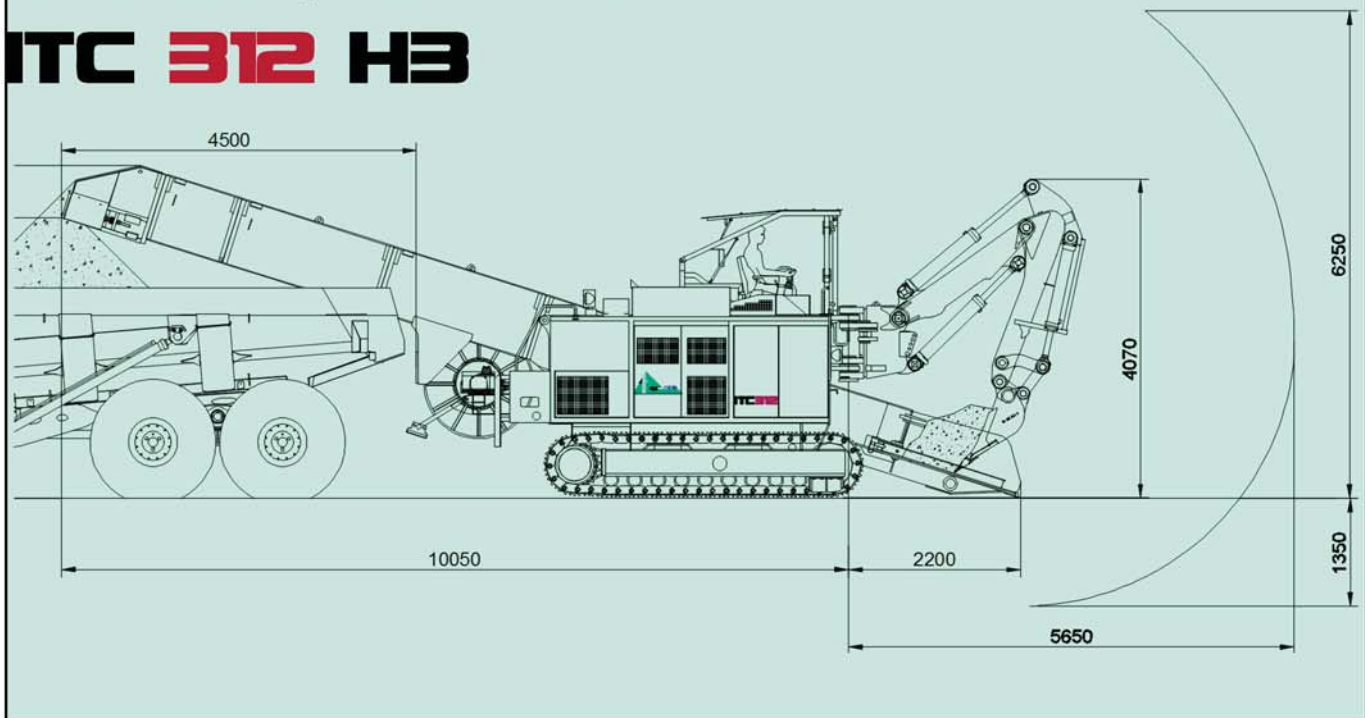

MAIN DATA

Base Machine: model	ITC	312 H3
Maximum chassis width	mm	2350
Apron throat width	mm	770
Electric drive power (400V-50Hz)	kW	90
Power output	kW	112
Driving speed	km/h	0-3,6
Conveyor chain speed	m/s	0.5
Loading capacity	m ³ /min	3-5
Specific ground pressure	kp/cm ²	1.0
Traction power	kN	280
Weight	t	28



Loading on Dumper Terex TA 35