

Tunnel Dump Truck

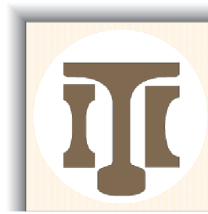

ITC

INTERTECHNO TUNNELLING-
EQUIPMENT COMMERCIAL SA

ITC10'000A #107'008



Informations

- Tunnel articulated Dump Truck PAUS model ITC 10'000A with all wheel drive and reverse seat for interchangeable structures.

- Construction year 2007
- Diesel drive 1'444 h

Technical data ITC 10'000A

Chassis

- Divided chassis with articulated joint and swinging front axle, articulated-joint lock, stable chassis frame welded out of high-quality sheet metal and sectional steel

Engine

- Water cooled, turbocharged, intercooling DEUTZ Diesel engine TCD2013, Dry filter with preliminary filter.
- Rated power : 173 kW at 2'300 RPM
- Option:
 - Soot filter.

Electric system

- Electric system 24 V. Generator 28V, 35 A, battery 2 x 120 Ah, two headlights each front and rear, one working headlight

Axles

- Kessler planetary rigid axles with enclosed multiple-disc brakes Rear axle fixed, front axle swingingly mounted to the vehicle frame.

Drive line

- Industrial full powershift single stage torque converter
- 4-speed-change-on-the move gear box, shiftable under load, with mechanic gearshift, all-wheel drive.
- 4x single tire 16.00 R 25.

Brakes installation

- Hydraulic two-circuit pump storage brake system, with oil-immersed multiple-disc brakes enclosed in the axle box.
- Brake-pressure control by brake-circuit pressure gauge in driver's stand
- Hydraulic spring-loaded parking brake effective as slide-saddle brake at the axle input of the rear axle.

Steering

- Central articulated joint with swinging front axle, pendulum angle +/- 10°,
- steering angle +/- 42°, Two double-effective steering cylinders
- Hydraulic caster-wheel steering, steering pump, steering orbitrol
- emergency-steering features

Inside turn radius 4'350 mm
Outside turn radius 7'250 mm

Special Body Volume

- Rear-tipping skip,
- skip volume 10,5 m³ struck, 12 m³ heaped,
- two double-effective tipping cylinders

Interchangeable superstructures

- Rock body
- Concrete mixer
- Service platform with/without crane
- Areal basket, etc

Driver Stand

- Closed driver's stand
- ROPS/FOPS cab with protection grid, body side.
- Comfortable driver's seat with safety belt, hydraulically damped, adjustable, rotary driver's seat can be swiveled for 180° for two drivings
- Standard instruments, automatic engine control for two driving directions easily accessible operating devices,
- The instruments and supervisory devices are installed in switch boxes
- Back alarm
- Position light
- Fire extinguisher

Weight

empty weight: 18,0 to
perm. total weight: 38,0 to
payload: 20,0 to
axle load front: 18,0 to
axle load rear: 20,0 to

Further details of attachments and accessories available upon request.

PAUS
...the people who care

Actual configuration

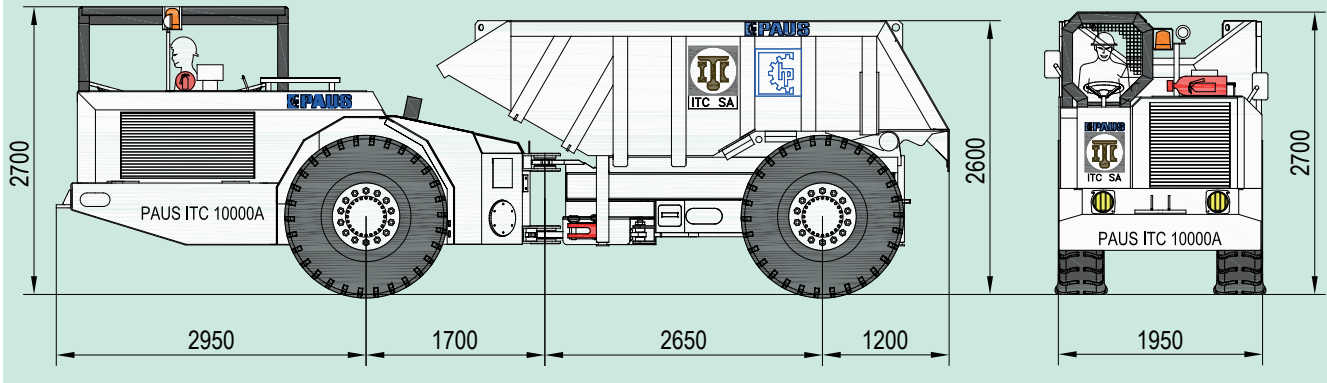

ITC
 INTERTECHNO TUNNELLING-
 EQUIPMENT COMMERCIAL SA



PAUS
...the people who care

ITC - Intertechno Tunnelling-Equipment Commercial SA · 122, rue de la Fusion · CH-1920 Martigny · Tel +41-277 222 191 · Fax +41-277 222 185
 Hermann Paus Maschinenfabrik GmbH · Siemensstr. 1-9 · D-48488 Emsbüren · Tel +49-5903 707 0 · Fax +49-5903 707 33
 Internet: <http://www.itcsa.com> - email: info@itcsa.com & www.paus.de - mail@paus.de