

Tunnel Dump Truck



ITC

INTERTECHNO TUNNELLING-
EQUIPMENT COMMERCIAL SA

ITC10'500 #424'245



Informations

- Tunnel articulated Dump Truck PAUS model ITC 10'500 with all wheel drive and reverse seat.
- Construction year 2024
- Diesel drive 0 h

Technical data ITC 10'000A

Chassis

- Divided chassis with articulated joint and swinging front axle, articulated-joint lock, stable chassis frame welded out of high-quality sheet metal and sectional steel

Engine

- Water cooled, turbocharged, intercooling DEUTZ Diesel engine TCD 7.8 L6, Dry filter with preliminary filter.
- EU Stage V / EPA Tier 4F
- Rated power : 225 kW at 2'200 RPM

Electric system

- Electric system 24 V. Generator 28V, 35 A, battery 2 x 120 Ah.
- 4 headlights LED each front and rear, one working headlight LED on cab.

Axles

- Kessler planetary rigid axles with enclosed multiple-disc brakes Rear axle fixed, front axle swingingly mounted to the vehicle frame.

Drive line

- Industrial full powershift single stage torque converter
- 4 Automatic speed change on the move gear box, shiftable under load
- all-wheel drive.
- 4x single tire 16.00 R 25.

Brakes installation

- Hydraulic two-circuit pump storage brake system, with oil-immersed multiple-disc brakes enclosed in the axle box.
- Brake-pressure control by brake-circuit pressure gauge in driver's stand
- Hydraulic spring-loaded parking brake effective as slide-saddle brake at the axle input of the rear axle.

Steering

- Central articulated joint with swinging front axle, pendulum angle +/- 8°,
 - steering angle +/- 42°, Two double-effective steering cylinders
 - Hydraulic caster-wheel steering, steering pump, steering orbitrol
 - emergency-steering features
- | | |
|---------------------|----------|
| Inside turn radius | 4'850 mm |
| Outside turn radius | 7'650 mm |

Special Body Volume

- Rear-tipping skip,
- skip volume 10 m³ struck, 11,5 m³ heaped,
- two double-effective tipping cylinders

Driver Stand

- Closed driver's stand
- ROPS/FOPS cab with protection grid, body side.
- Comfortable driver's seat with safety belt, hydraulically damped, adjustable, rotary driver's seat can be swiveled for 180° for two drivings
- Standard instruments, automatic engine control for two driving directions easily accessible operating devices
- Joystick control on right armrest.
- The instruments and supervisory devices are installed in switch boxes
- Back alarm
- Position light
- Fire extinguisher manual and Automatic
- Central greasing device
- Cab AC and heating

Weight

operating weight:	22,9 to
payload:	22,0 to
axle load front:	21,0 to
axle load rear:	23,0 to

Subject to modification without prior notice.

Actual configuration

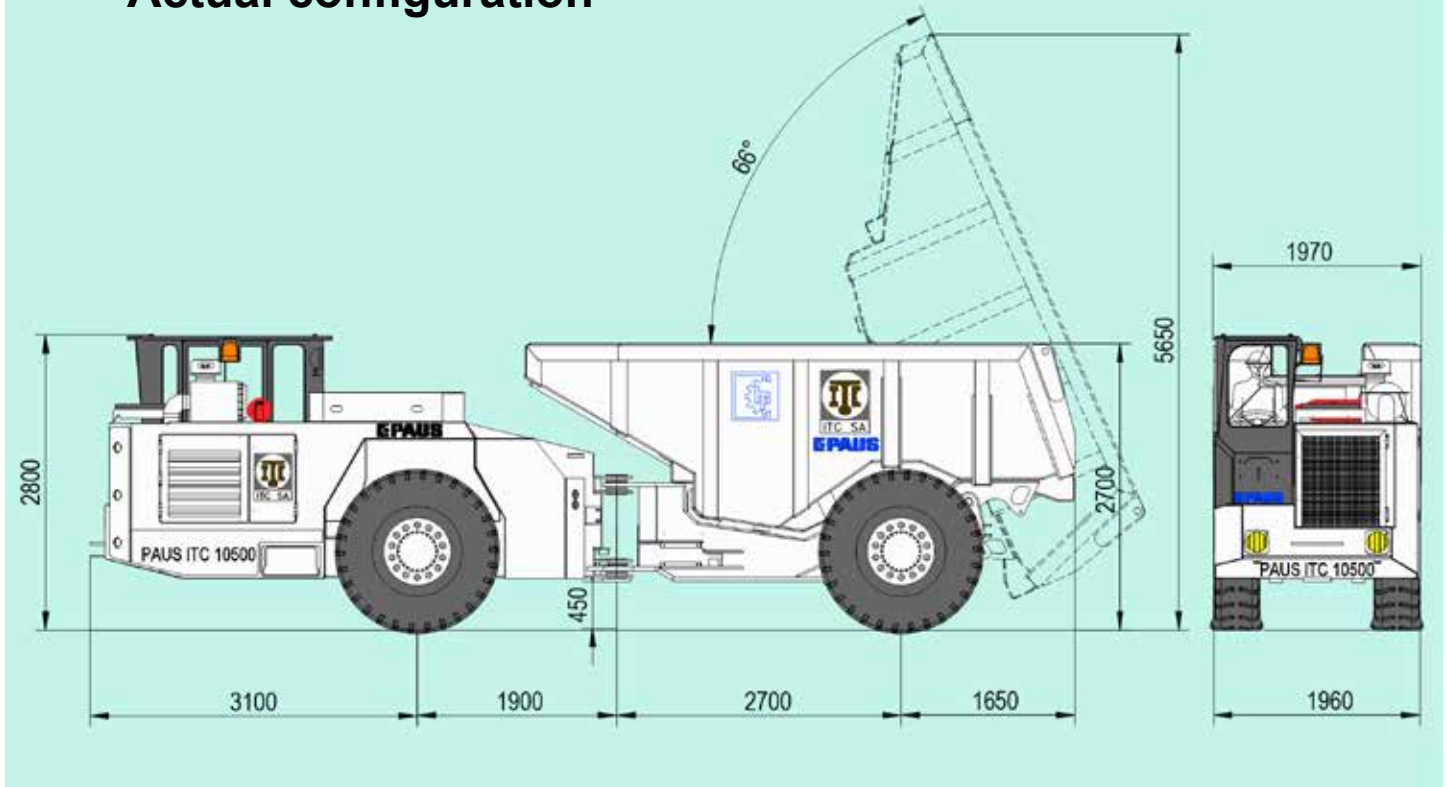

ITC
 INTERTECHNO TUNNELLING-
 EQUIPMENT COMMERCIAL SA



ITC- Intertechno Tunnelling-Equipment Commercial SA · 122, rue de la Fusion · CH-1920 Martigny · Tel +41-277 222 191 · Fax +41-277 222 185
 Hermann Paus Maschinenfabrik GmbH · Siemensstr. 1-9 · D-48488 Emsbüren · Tel +49-5903 707 0 · Fax +49-5903 707 33
 Internet: <http://www.itcsa.com> - email: info@itcsa.com & www.paus.de - mail@paus.de

I:\Paus\Dumper ITC\Disponibile\10500_424-245\Prospectus\P10500_424-245.midd - 03.12.2024